

BACKALARM™ MEDIUM DUTY

For trucks, buses, coaches, industrial vehicles & light, mobile plant.
Carefully optimised frequency/loudness characteristics make these units clearly audible under typical working conditions without being a nuisance in the urban/highway environment.

- **LIFETIME WARRENTY**
- Conforms to SAE J994 environmental standards
- Tough, durable, guaranteed waterproof (IP68)
- Solid state, spark free electronics.
- Epoxy sealed against mud, water & vibration.
- Can be steam cleaned * pressure hosed.
- CE & 'e' marked (EMC)

6562/1010	MEDIUM DUTY BACKALARM
Voltage - 12 -24 volts (DC)	
Amps - 0.2A	
Volume - 82 - 102 dB(A) @ 1m	
Frequency - 1.25 KHz	
Dimensions - W = 100mm, H = 72mm, D = 32mm	
Hole centres @ 76 - 82mm	

BACKALARM™ MEDIUM DUTY

For trucks, buses, coaches, industrial vehicles & light, mobile plant.
Carefully optimised frequency/loudness characteristics make these units clearly audible under typical working conditions without being a nuisance in the urban/highway environment.

- **LIFETIME WARRENTY**
- Conforms to SAE J994 environmental standards
- Tough, durable, guaranteed waterproof (IP68)
- Solid state, spark free electronics.
- Epoxy sealed against mud, water & vibration.
- Can be steam cleaned * pressure hosed.
- CE & 'e' marked (EMC)

6562/109	MEDIUM DUTY BACKALARM
Voltage - 12 -24 volts (DC)	
Amps - 0.2A	
Volume - 97 dB(A) @ 1m	
Frequency - 1.4 KHz	
Dimensions - W = 105mm, H = 65mm, D = 32mm	
Hole centres @ 75 - 85mm	

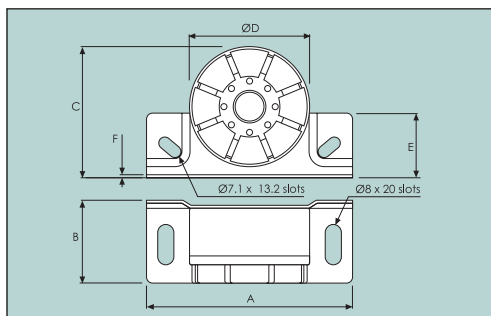

REVERSING ALARM

Rated to IP67.
Impervious to mud, dust & water.
Withstands steam clean & pressure washer.
Pulse tone @ 97dB (A) @ 1.2m.
voltage spike protected.

	A	B	C	D	E	F	G	H
6563/097	10-100v (200mA max)				Weight 190g/6.7oz			
METRIC (mm)	101.6	41.0	63.0	60.0	31.3	1.5		
IMPERIAL (ins)	4.0	1.61	2.5	2.36	1.23	0.06		

BRIGADE®



BRIGADE®

