

PARTS LIST			
ITEM	QTY	PART NUMBER	DESCRIPTION
1	1	2217-006-1	CARBON STEEL HINGE BASE
2	1	2217-006-2	BRASS BEARING WASHER
3	1	2219-006-1	CARBON STEEL MOUNTING BLOCK
4	1	2219-005-2	SS GREASE NIPPLE

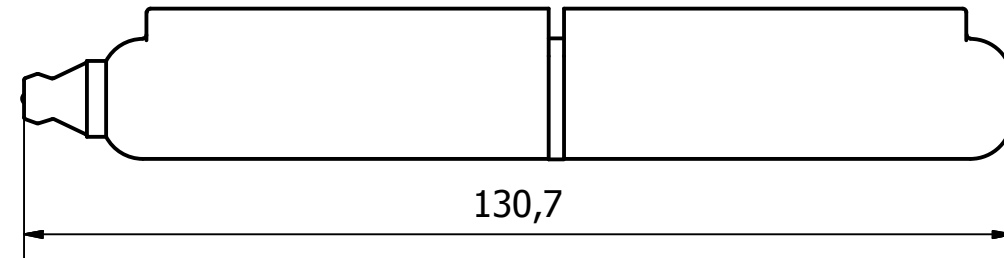
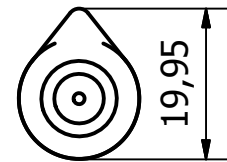
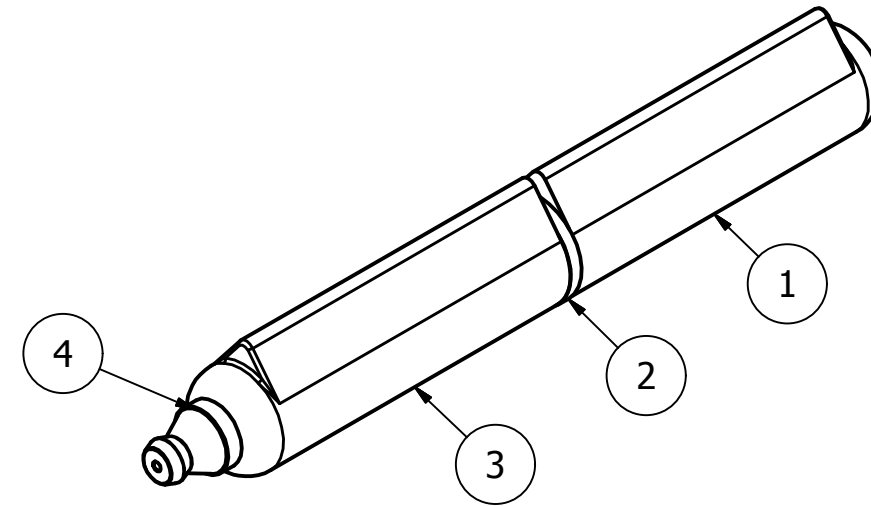
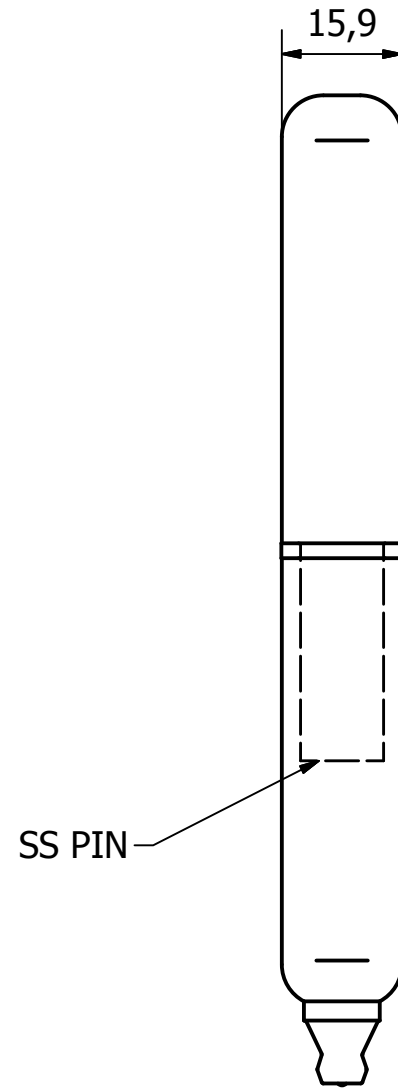

1	VALIDATION COMPLETE	20/01/2017	A.P
REV	DESCRIPTION	DATE	APPROVED

GENERAL TOLERANCES ON LENGTHS
0.5 - 6 ± 0.1mm
6 - 30 ± 0.2mm
30 - 120 ± 0.3mm
120 - 400 ± 0.5mm
400 - 1000 ± 0.8mm
1000 - 1200 ± 1.2mm
2000 - 4000 ± 2.0mm

ALBERT JAGGER LTD  
 GREEN LANE  
 WALSALL PHONE: 01922 471000  
 WEST MIDLANDS FAX: 01922 648021  
 WS2 8HG

THIS DRAWING & THE DESIGN SHOWN ARE THE PROPERTY OF ALBERT JAGGER LTD AND MUST NOT BE USED OR COPIED BY A THIRD PARTY WITHOUT PERMISSION

DRAWN BY  
U.F

CHECKED BY  
A.P



SCALE  
1 : 1

MATERIAL  
-

MASS  
0.184 kg

FINISH  
NATURAL

Date  
14/11/2016

ALL DIMS IN MM UNLESS STATED DO NOT SCALE

A3



WELD ON LIFT - OFF HINGE - 130.7 O/A SS PIN AND GREASE NIPPLE

2219-0160

Edition	Sheet
1	1 / 1