

PARTS LIST			
ITEM	QTY	PART NUMBER	DESCRIPTION
1	1	0288-003-2	BASE PLATE
2	1	0288-003-3	Z/P REVIT PIN
3	1	0288-003-4	Z/P COIL SPRING
4	1	0288-003-1	Z/P SEAT BRACKET

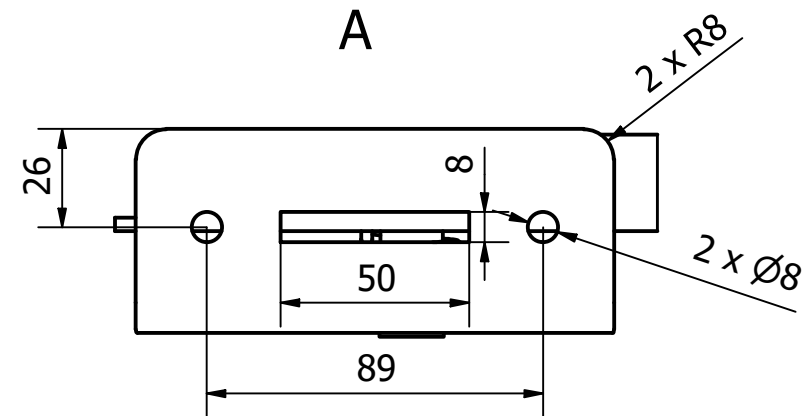
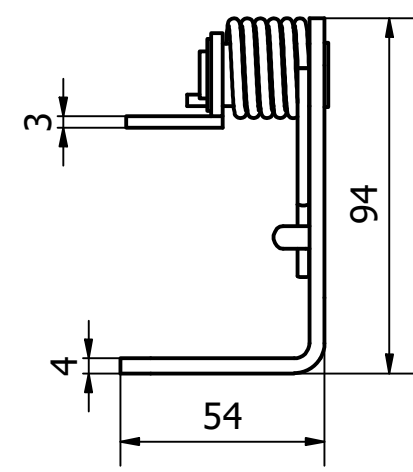
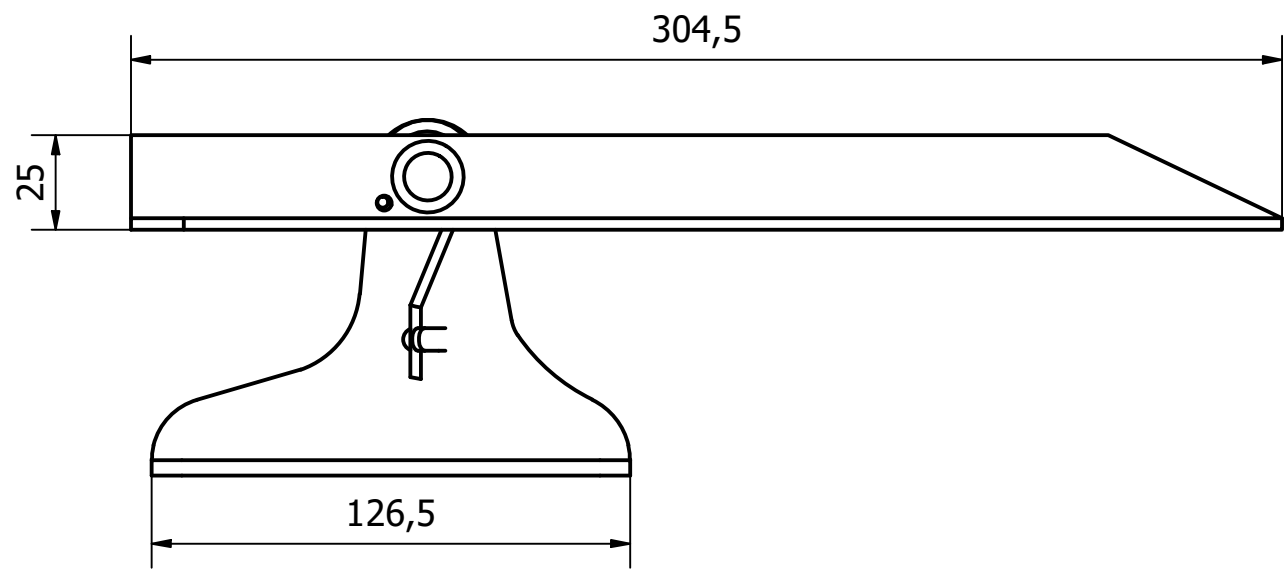
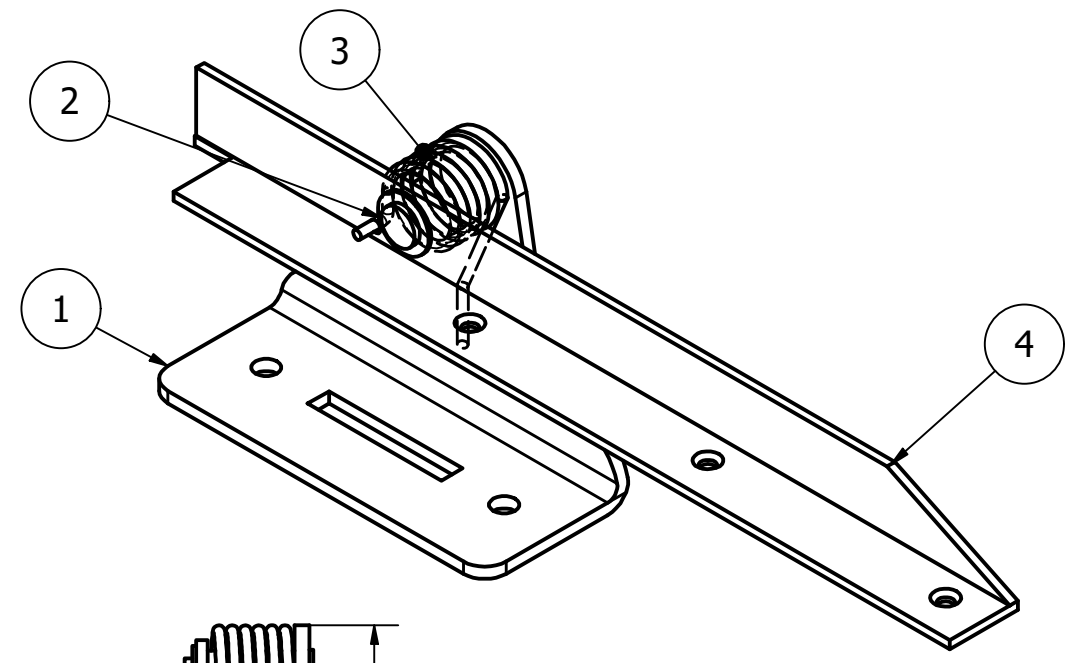
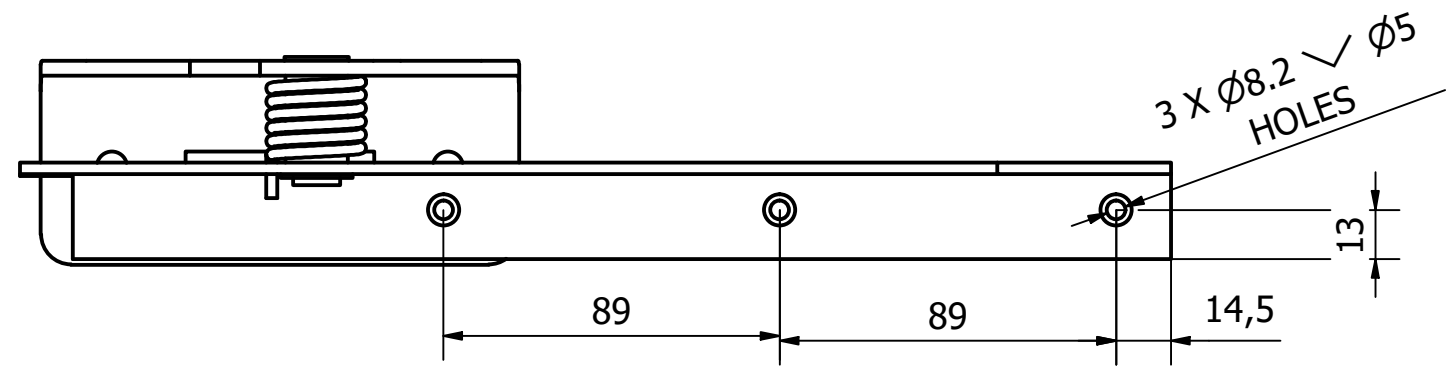

VIEW A

NOTE:  
 MAXIMUM SEAT WIDTH @ 450MM  
 FINISH - ZINC PLATED TO 8 MICRONS THICK WITH JS500 TOP COAT

GENERAL TOLERANCES ON LENGTHS
0.5 - 6 ± 0.1mm
6 - 30 ± 0.2mm
30 - 120 ± 0.3mm
120 - 400 ± 0.5mm
400 - 1000 ± 0.8mm
1000 - 2000 ± 1.2mm
2000 - 4000 ± 2.0mm

ALBERT JAGGER LTD  
 GREEN LANE  
 WALSALL WEST MIDLANDS WS2 8HG  
 PHONE: 01922 471000  
 FAX: 01922 648021

THIS DRAWING & THE DESIGN SHOWN ARE THE PROPERTY OF ALBERT JAGGER LTD AND MUST NOT BE USED OR COPIED BY A THIRD PARTY WITHOUT PERMISSION

DRAWN BY  
K.M

CHECKED BY  
A.P

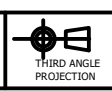

SCALE  
1 : 2

MATERIAL  
M/STEEL

MASS  
0.735 kg

FINISH  
SEE NOTE

Date  
02/10/2020

ALL DIMS IN MM UNLESS STATED DO NOT SCALE

A3

1	VALIDATION COMPLETE	02/12/21	C.H
REV	DESCRIPTION	DATE	APPROVED



L/H TIP UP SEAT FITTING - 304.5	
0288-003	Edition 1 / Sheet 1 / 1