

PARTS LIST			
ITEM	QTY	PART NUMBER	DESCRIPTION
1	1	2212-003-2	S/S M6 SCREW - 64.5 O/A
2	1	4291-001-3	INTERNAL BRASS BALL
3	1	2212-003-3	STEEL SPRING
4	1	2212-003-4	S/S KEY WASHER
5	1	2212-003-5	S/S M6 NUT
6	2	2212-004-1	MALLEABLE IRON HINGE FLAP

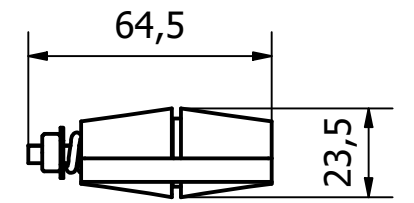
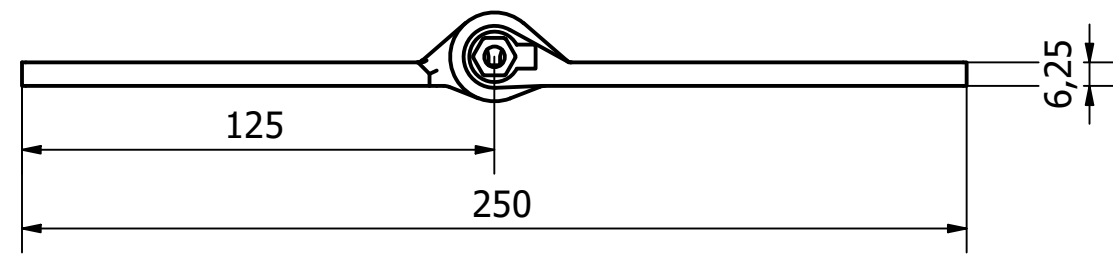
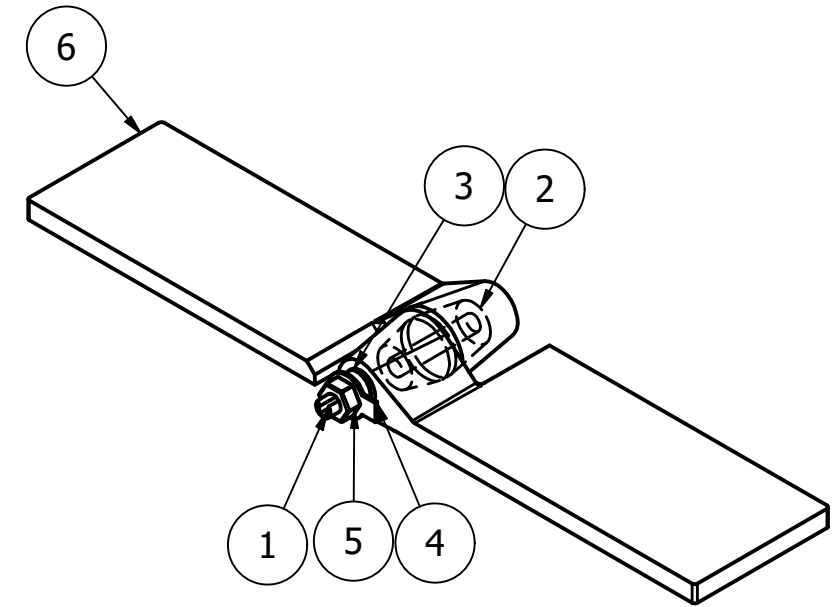
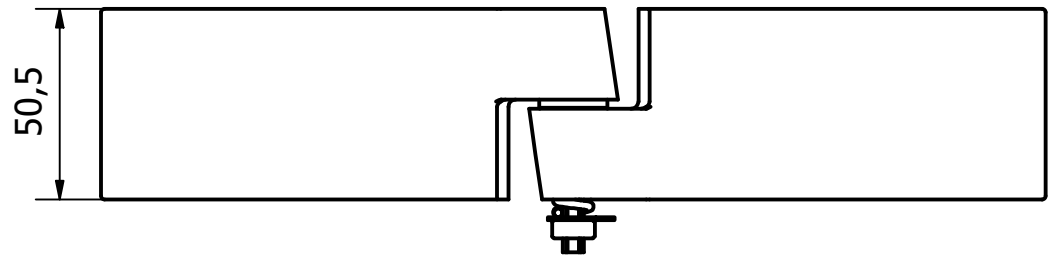

NOTE:

MALLEABLE IRON, SELF COLOUR, 270° OPENING
JOINTED AND TENSIONED WITH COIL SPRING
& BRASS BALL ON DETACHABLE PIN

FINISH:

ZINC PLATED TO 8 MICRONS THICK WITH CLEAR PASSIVATION

GENERAL TOLERANCES ON LENGTHS
0.5 - 6 ± 0.1mm
6 - 30 ± 0.2mm
30 - 120 ± 0.3mm
120 - 400 ± 0.5mm
400 - 1000 ± 0.8mm
1000 - 1200 ± 1.2mm
2000 - 4000 ± 2.0mm

ALBERT JAGGER LTD
GREEN LANE
WALSALL PHONE: 01922 471000
WEST MIDLANDS FAX: 01922 648021
WS2 8HG

THIS DRAWING & THE DESIGN SHOWN
ARE THE PROPERTY OF ALBERT JAGGER LTD
AND MUST NOT BE USED OR COPIED BY A
THIRD PARTY WITHOUT PERMISSION

DRAWN BY
U.F

CHECKED BY
A.P

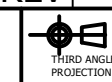

SCALE
1 : 2

MATERIAL
-

MASS
0.646 kg

FINISH
SEE NOTE

Date
26/04/2021

ALL DIMS IN MM
UNLESS STATED
DO NOT SCALE

A3

1	VALIDATION COMPLETE	26/04/21	A.P
REV	DESCRIPTION	DATE	APPROVED
	RH SELF ALIGNING HINGE - ADJ TENSION		
	2212-104	Edition 1	Sheet 1 / 1