

PARTS LIST			
ITEM	QTY	PART NUMBER	DESCRIPTION
1	1	5000-840-1	ZINC DIE-CAST HOUSING - CHROME PLATED
2	1	5000-840-2	ZINC DIE-CAST SQUARE - CHROME PLATED
3	1	5000-840-3	RUBBER NBR GASKET
4	1	5000-840-4	M/STEEL CAM - ZINC PLATED
5	1	5000-840-5	ZINC DIE-CAST DOUBLE BIT - SELF-COLOUR
6	1	5000-840-6	ZINC DIE-CAST NUT- SELF COLOUR
7	1	5000-840-7	M/STEEL M6 SCREW - ZINC PLATED
8	1	5000-840-8	RUBBER NBR O RING - BLACK
9	1	5000-840-9	RUBBER NBR O RING - BLACK
10	1	5000-840-10	STAINLESS STEEL 304 WASHER

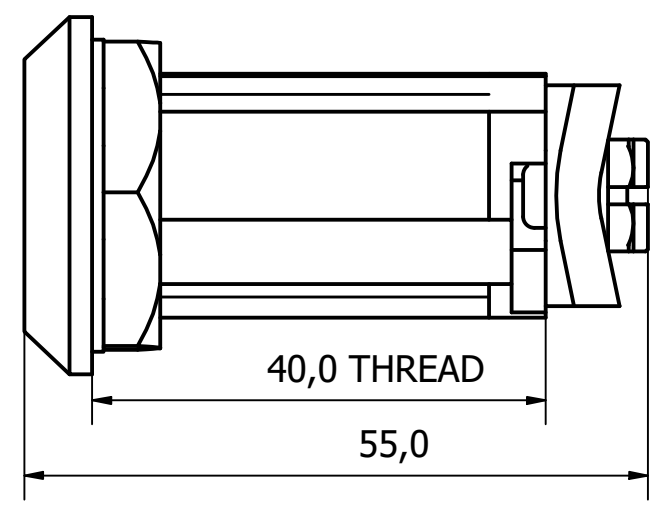
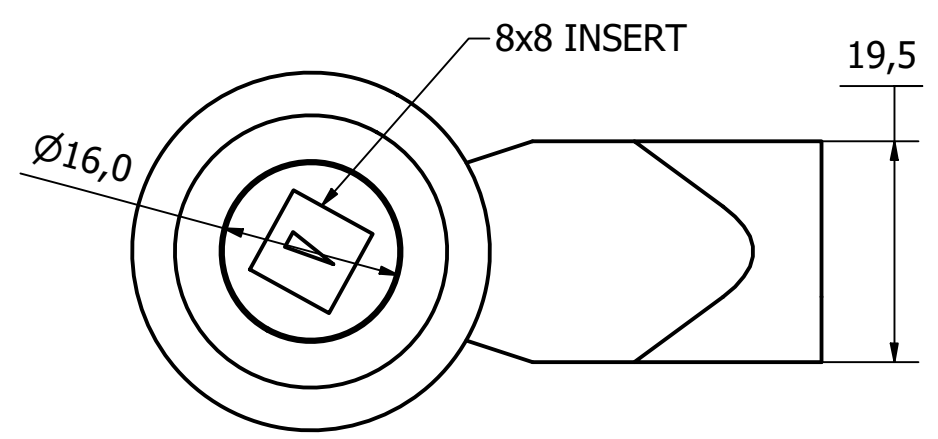

2	PARTS LIST CHANGED	12/07/19	A.P
REV	DESCRIPTION	DATE	APPROVED

GENERAL TOLERANCES ON LENGTHS
0.5 - 6 ± 0.1mm
6 - 30 ± 0.2mm
30 - 120 ± 0.3mm
120 - 400 ± 0.5mm
400 - 1000 ± 0.8mm
1000 - 2000 ± 1.2mm
2000 - 4000 ± 2.0mm

ALBERT JAGGER LTD
 GREEN LANE
 WALSALL PHONE: 01922 471000
 WEST MIDLANDS FAX: 01922 648021
 WS2 8HG

THIS DRAWING & THE DESIGN SHOWN ARE THE PROPERTY OF ALBERT JAGGER LTD AND MUST NOT BE USED OR COPIED BY A THIRD PARTY WITHOUT PERMISSION

DRAWN BY
A.S

CHECKED BY
A.P



SCALE
1.5:1

MATERIAL
SEE DRAWING

MASS
0.156 kg

FINISH
SEE DRAWING

Date
27/06/2019

ALL DIMS IN MM UNLESS STATED DO NOT SCALE

A3



QUARTER TURN LOCK

5000-840

Edition 2

Sheet 1 / 1