

PARTS LIST			
ITEM	QTY	PART NUMBER	DESCRIPTION
1	1	5589-552	M/STEEL HANDLE DISH - P/C BLACK
2	1	5589-375-1	BLACK RUBBER DISH GASKET
3	1	5589-375-2	ZINC DIE-CAST TEE HANDLE - POLISHED CHROME

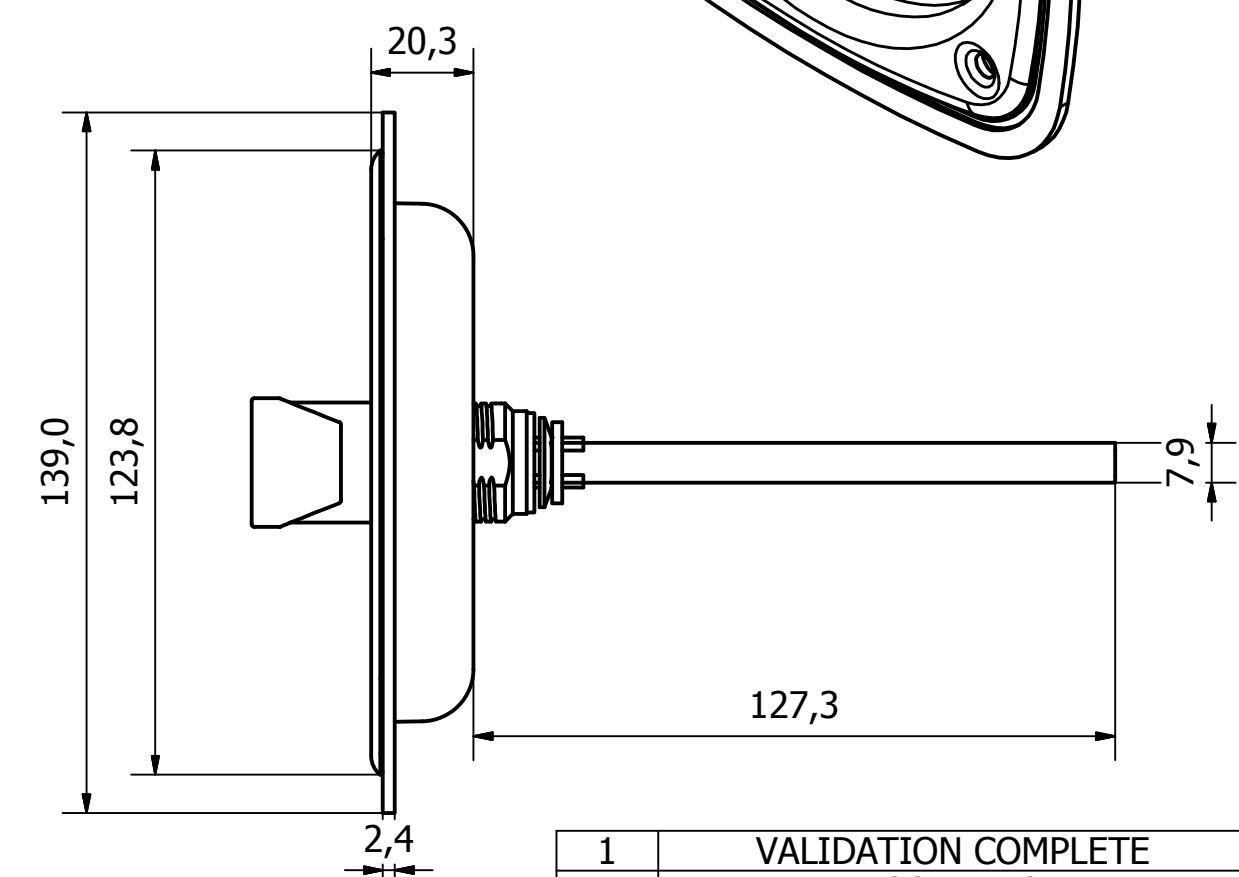
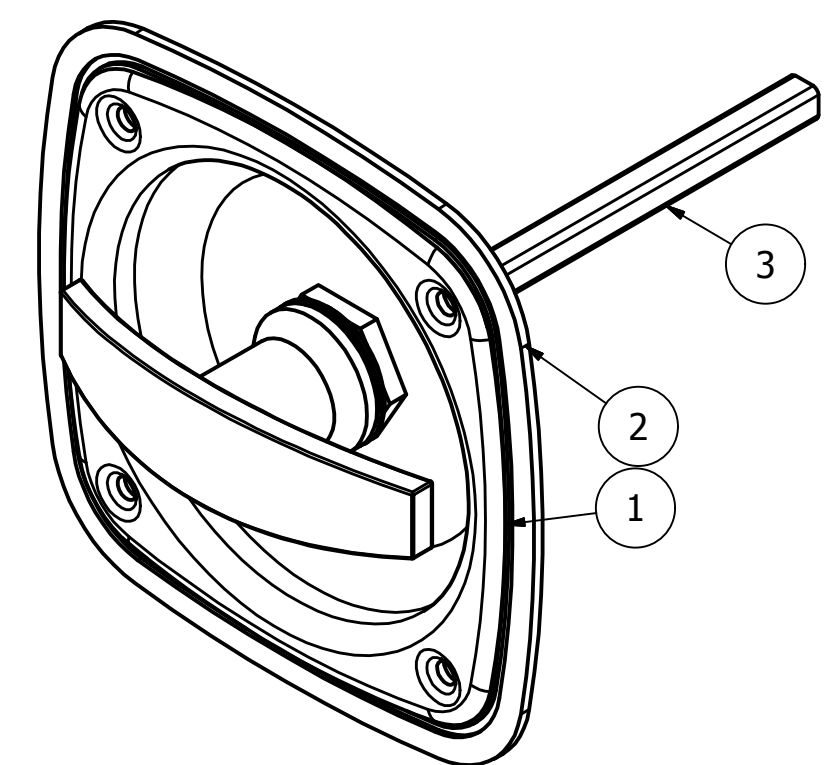

4 x Ø5,2 HOLES

GENERAL TOLERANCES ON LENGTHS
0.5 - 6 ± 0.1mm
6 - 30 ± 0.2mm
30 - 120 ± 0.3mm
120 - 400 ± 0.5mm
400 - 1000 ± 0.8mm
1000 - 2000 ± 1.2mm
2000 - 4000 ± 2.0mm

ALBERT JAGGER LTD
 GREEN LANE
 WALSALL PHONE: 01922 471000
 WEST MIDLANDS FAX: 01922 648021
 WS2 8HG

THIS DRAWING & THE DESIGN SHOWN ARE THE PROPERTY OF ALBERT JAGGER LTD AND MUST NOT BE USED OR COPIED BY A THIRD PARTY WITHOUT PERMISSION

DRAWN BY
U.F

CHECKED BY
A.P

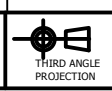

SCALE
1:1.5

MATERIAL
SEE TABLE

MASS
0.440 kg

FINISH
SEE TABLE

Date
08/11/2017

ALL DIMS IN MM UNLESS STATED DO NOT SCALE

A3

1	VALIDATION COMPLETE	08/11/17	A.P
REV	DESCRIPTION	DATE	APPROVED



NON LOCKING RECESSED 'T' HANDLE
 5589-375

Edition	Sheet
1	1 / 1